

RESPONSE OF A MEDIUM VOLTAGE CURRENT LIMITING FUSE OF SMALL SIZE TESTED AS GENERAL PURPOSE AND FULL-RANGE TYPE.

Alfonso Avila Ramírez.

Corporativo Arian, S.A. de C.V., Hidalgo 26 Santa Ana Tlacotenco, Milpa Alta D.F., México C.P. 12900
www.arian.com.mx, arian@arian.com.mx

Abstract: This paper describes laboratory investigations on a distribution current-limiting fuse of relatively reduced dimensions applied in an enclosure with restricted air flow surrounding it, tested as general purpose and full-range types respectively. The most important differences found in both cases are closely related with the application of the minimum interrupting current I_3 which was determined following the criteria established in the IEEE STD C37.41-2000 [1]. There is not a great difference between their magnitudes but its thermal effect is determinant for the satisfactory performance of them. However as we have found, if only the fuse body material is changed it is quite possible to have in only one model both types of fuses taking into account that all the others components of it have been chosen and designed in the best possible way.

Keywords: FEP_s Fuse Enclosure Packages

1. Introduction

The IEEE std C37.41-2000 specifies design test requirements for high-voltage fuses amongst which are included the distribution and power class current-limiting type fuses.

The distribution type current-limiting fuse described here, was designed to be used in an enclosure with relatively free air circulation within the enclosure trying to satisfy the corresponding interrupting test series 1, 2 and 3 indicated in the paragraph 6.6.

In particular the test series 3 was carried out following carefully the criteria indicated in the paragraphs 6.6.2, 6.6.3 and 6.7. Paragraph 6.6.2 describes an alternate test method for series 3 using a low-voltage source for the first part of the test and a high-voltage source for the second part of the test

6.6.3 describes the method for series 3 tests on full-range current-limiting fuses.

6.7 gives a description of interrupting tests for FEP's using current-limiting type indoor distribution and power class fuses.

2. Construction.

The current-limiting fuse described in this paper has been designed for nominal current and voltage ratings of the 30 A and 8.3 kV A.C. respectively.

Because of its small size, Fig 1, it has only one silver ribbon wound with M-spot made of eutectic tin alloy located on its middle, Fig 2.

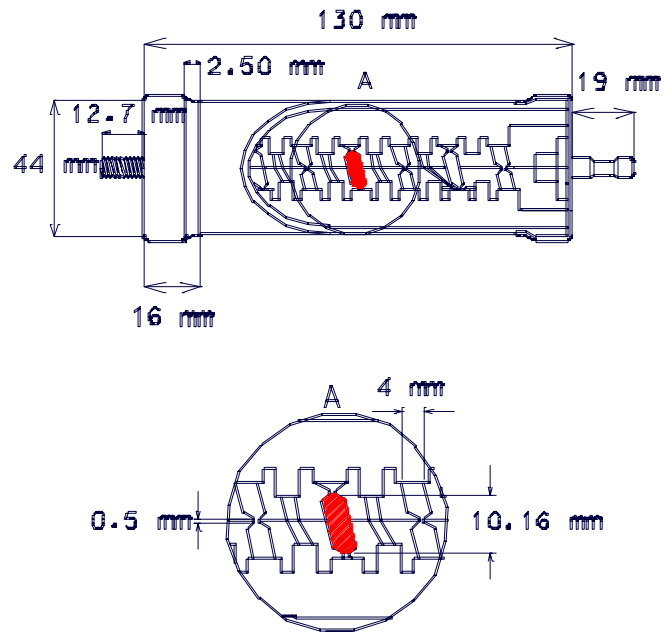

Figure1: Medium Voltage Current-Limiting Fuse

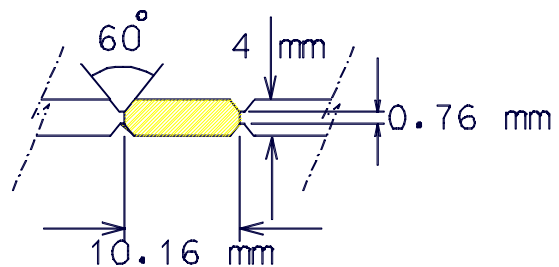

Fig 2. Silver Ribbon wound with M-spot .

Also and connected in parallel with it are two auxiliary elements made of silver wire for controlling the arcing in more than one point [2]. The element support is made of mica (aluminosilicate-mineral) of optimized design for continuous operating temperature of 500°C and dielectric strength of 13 kV/mm at 400 °C.

The fuse body is made of glass epoxy tubing NEMA G-11 for a continuous operating temperature of 150 °C and 205 °C for short time. In order to have a good mechanical strength and a maximum heat dissipation by conduction to the end terminals, the end cylindrical caps are made of cooper.

The core (spider) has the right concentricity with the cylindrical body. This condition added to an adequate compactness of the quartz sand [3] of an average size of 0.45mm, improves the behavior of the fuse under steady-state operating conditions, distributing uniformly the axial and radial dissipation mainly and under short-circuit conditions, facing satisfactorily its thermal, dielectrical and mechanical effects.

As these type of fuses are applied in underground circuits to protect pad-mounted transformers, its fuse-body has an external semi-conducting wrap that provides a fully shielded system.

Also we have avoided to use the polluting agents like the flux for soldering metallic components located inside the cylindrical body after assembly due to its disastrous effects.

3. Heating Process

For the purpose of our experimental study directed basically to the response of the fuse to the small overcurrents comprised between the minimum breaking current I_3 and the minimum melting current, we consider the heating process a steady state thermal phenomenon, so the heat generated within the fuse, is dissipated to the surroundings by conduction and convection due to the enclosure (FEP) used under normal application operating conditions and also during all the tests made in our investigation.

The equation developed by Verdet in 1872 for the temperature in an element section [4] heated by electric current is:

$$Ks \frac{d^2T}{dx^2} - \frac{T}{g} + \frac{I^2 \rho_o (1 + \alpha T)}{s} = 0 \quad (1)$$

↑ Axial heat conduction loss
↙ Heat loss from surface
↘ Internal heat generation

In this ordinary differential equation:

K = thermal conductivity of the element metal

s = cross-sectional area of the fuse element

T = temperature rise above ambient

g = thermal resistance per unit length

ρ_o = resistivity at ambient temperature.

α = temperature coefficient of resistivity

In the above referenced paper [4] are described the solutions of the differential equation (1) that in the case of low currents the temperature distribution is governed by hyperbolic functions and also are shown the calculations of:

- Heat transfer by conduction to the ends of the section taking into account that the whole element is formed by a combination in series of a given number of such sections.
- The radial thermal resistance.
- Effect of field distortion.
- Heat generated in the caps, and
- Heat lost to end assemblies.

In order to determine the more convenient I_3 current magnitudes, we made a series of melting tests in the long-time zone of operation of the time-current characteristics previously defined by experimentation (Figure 3). Making some changes in an orderly way and with only one change each time on the central design parameters.

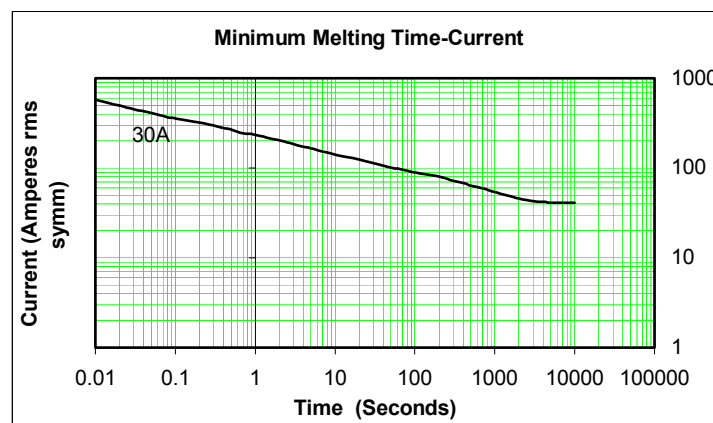

Figure 3 Melting time-current curve

The most relevant changes and results were:

Variation of the neck cross-section and the ratio between the width (b) of the neck and the width of the strip (B) looking for a ratio of five in order to reduce additionally the arcing energy

$$\int Va ia dt$$

generated [5] during the short-circuit tests.

In tables 1 and 2 are presented some significative variations attained.

Cross section (mm ²)	Maximum temperature rise (°C)	Melting time (minutes)
0.11375	73.12	33
0.16912	146.70	67

Table 1 Testing current = 43 A.

Ratio $\frac{B}{b}$	Maximum temperature rise (°C)	Melting time (minutes)
8	131.87	142
5.333	112.5	123

Table 2 Testing current = 41 A.

Average grain size of the quartz sand and its influence on the magnitude of melting time, maximum temperature generated and the behavior of the fuse link when is tested with I₃ at rated voltage [6], [7], [8] See table 3

Average Ø of quartz sand (mm)	Maximum temperature rise (°C)	Melting time (minutes)
0.70	141.87	871
0.45	119.83	715

Table 3. Results attained applying increases of melting current of 5% with a final magnitude of 30A

The quantity of alloy chosen for the M-spot [9] and its influence on the melting time and temperature-rise. See table 4

Weight of the alloy added (p.u.)	Maximum temperature rise (°C)	Melting time (minutes)
1	66.36	72
0.36	101.98	71

Table 4. Testing Current = 41A

4. Operating temperature within the enclosure and I₃ current magnitudes

The rated maximum application temperature chosen for the fuse link within the enclosure was 77 °C.

In the case of fuse links considered as general purpose type and applying the established criteria in the paragraphs 6.6.2.2, 6.7.2.1 (FEP type 1C) and 6.7.4 of the IEEE std. Referenced in [1], starting with a melting current of 41 A, taken from the melting time-current curve, the I₃ current obtained a final magnitude of 32.5 A approx.

The derating factor recommended in [10] was:

$$0.4\% / ^\circ\text{C}$$

percentage reduction factor = (77-25) 0.4 = 20.8%

$$\Rightarrow I_3 = 41 (1-0.208) \approx 32.5 \text{ A}$$

When the fuse was considered as full-range type the increases of current steps from a given value until its final value when the fuse link melted, was applied the method described in 6.6.3.1 of the above indicated std.

In both cases the minimum number of test made with the final model was at least five.

The results of the test for each case are shown in table 6 and 7.

I ₃ current magnitude (A)	Maximum temperature rise (°C)	Melting time (minutes)
32.5	160.24	199

Table 6. General Purpose type fuse (initial temperature = (77°C)

Current steps (A)	Maximum * temperature rise (°C)	Melting time (minutes)
21	88.78	-----
22.5	93.40	-----
24	98.08	-----
25.5	101.98	-----
27	108.16	-----
28.5	113.30	-----
30	120.38	-----
31.5	142.44	-----
33	143.12	1115

Table 7. Full range type fuse (initial temperature = 77°C)

*For each current step, the temperature was considered stable when the temperature rise above ambient did not exceed 2% per hour.

Table 6 shows the final current magnitude I_3 applied to the general purpose type fuse and table 7 shows the current step values with its corresponding stabilized temperatures together with the final current and melting time determined for the full-range type fuse.

The highest current that a total of five fuses carried without melting was 31.5 A so:

$$I_3 = 0.9 (31.5) = 28.35 \text{ A and we use}$$

$$I_3 \approx 28.5 \text{ A.}$$

5. Breaking Tests and Results

The test series 1 2 and 3 were performed applying the methods described in 6.6 and 6.7 of the referenced IEEE std. The results were:

Test series 1

Test current: 50 kA rms symmetrical
 Test voltage: 8.31 kV
 Ambient Temperature: 30°C
 Oscillogram of one test

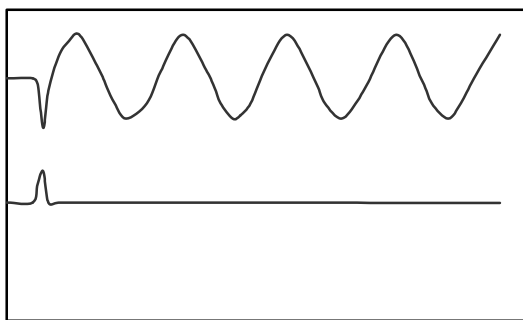

Figure 4. peak current: 5485 A
 peak voltage: 16.354 kV

Test series 2

Test current: 16.56 kA rms symmetrical
 Test voltage: 8.31 kV
 Temperature within the enclosure: 77°C

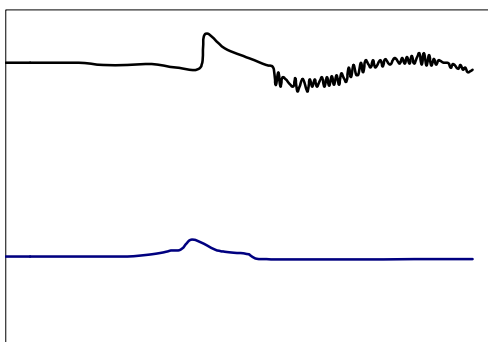

Figure 5 Peak current: 4.86 kA
 Peak voltage: 27 kV

Duration of recovery voltage after interruption = 60 seconds.

Test series 3

Considering The fuse as general purpose-type

Test current at low voltage { 32.5 A during 60 minutes
 37.4 A during 9 minutes

Test voltage applied after 69 minutes: 8.33 kV
 Temperature within the enclosure: 77°C
 The following oscillogram shows only the part of test made a 8.33 kV

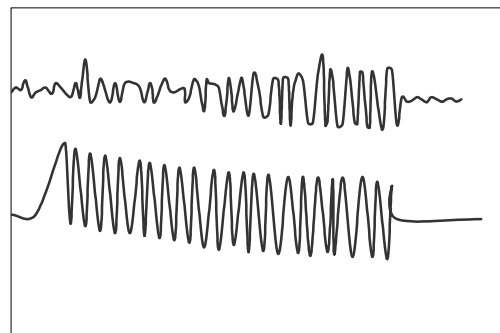

Figure 6 Peak voltage: 11.78 kV
 Melting time: 69 minutes
 Duration of recovery voltage after interruption: 10 minutes
 Number of tests : 2

Fuse link considered as full-range type

Test current at low voltage { 28.5 A during 60 minutes
 32.7 A during 30 minutes

Test voltage applied after 90 minutes: 8.33 kV
 Temperature within the enclosure: 77°C

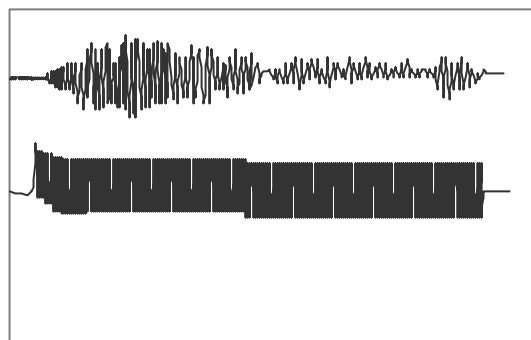

Figure 6

The fuse failed to open the medium voltage circuit after applying 28.5 and 32.7 A in the low voltage circuit

The tube of the fuse-body presented several burns without an intense carbonization on its inner wall.

By reasons of economy this was the only test made under the above described conditions.

Note: All the interrupting tests were carried out at the High Power Laboratory LAPEM of the Comisión Federal de Electricidad.

6. Conclusions

After all tests made, until now we conclude that our final model of fuse link failed to interrupt the I_3 testing current when it was considered as full-range type, it is possible to improve its response taking into account these remarks:

- To change the material for the tubing of the fuse-body. For instance to use NEMA Grade G-7 material.
- In order to assure the success of an optimized model it is necessary to avoid in its construction the use of polluting agents like: flakes of mica, iron oxide, and flux for soldering any metallic component located within the fuse body.
- The more convenient I_3 current magnitude for testing full range fuses requires the use of increases of current steps as small as possible although this condition spend more time

References.

[1] IEEE std C37.41-2000, "IEEE Standard Design Tests for High-Voltage Fuses, Distribution Enclosed Single-pole Air Switches, Fuse Disconnecting Switches, and Accessories"

[2] H.W. Mikulecky, "Current-Limiting Fuse with Full-Range clearing Ability", IEEE Transactions on Power Apparatus and Systems, Vol PAS-84 No 12, pp 1107-1112, December 1965

[3] Chen Su Tsing, "Research on the technique of Filling Quartz sand in Fuses", Third International Conference on electrical fuses and Their applications, Eindhoren, The Netherlands, pp 93-98, May 11-13 1987.

[4] R Willkins, "Simulation of Fuse link Temperature-Rise Tests", International Conference on Electric Fuses and their applications, pp 24-32, Trondheim 1984

[5] V. Narancic, M Braubonic, A-C Westrom, "The composite fuse- A new Technology for Current Limiting Fuses", 7th. IEEE/PES, Transmission and Distribution Conference and Exposition, pp 462-470 April 1-6 1979

[6] Sei-Hyun Lee et al, "The test method to acquire the optimal parameter for CL-Fuse" International Conference on Electric Fuses and their applications, pp 265-270, Torino Italy, September 20-22 1999

[7] H.V. Turner and C. Turner, "Phenomena occurring during the extinction of arc fuses", Electrical Research Association, pp 253-256, Leatherhed, England

[8] Aslak Ofte and W Rondeel, "Test procedures and Arcing phenomena in H.V. Fuse links Near the minimum breaking current", International conference on electric Fuses and their applications, pp 190-199, Trondheim, Norway June 13-15 1984

[9] M. Hofmann and Lindmayer, "Pre-calculation of time/current characteristics of "M"-effect fuse elements", Third International Conference on Electrical Fuses and Their applications, pp 30-38, Eindhoven, The Netherlands, May 11-13 1987.

[10] IEEE std C37.48-1997, "IEEE Guide for the application Operation, and Maintenance of High Voltage Fuses, distribution Enclosed Single-Pole Air Switches, and Accessories".