

Protection against fault arcs in low voltage distribution boards

J.G.J. Sloot ⁽¹⁾ and R.J. Ritsma ⁽²⁾

Eindhoven University of Technology ⁽¹⁾, Netherlands, j.g.j.sloot@tue.nl

Prof. Damstra Laboratory ⁽²⁾, Eaton Electric NV, Netherlands, r.ritsma@holec.nl

Abstract:

Modern low voltage distribution systems often are installed without main protection equipment on the low voltage side of distribution transformers; it is relied on the relay or fuse on the high voltage side of the transformers. This article demonstrates that such philosophy can result in long lasting voltage dips and failing protection. Practical cases of arc faults in main low voltage distribution installations are discussed, as well as laboratory experiments.

Keywords: electric fuse, fault arc, low voltage installations, voltage dips

1. Introduction

In the Netherlands, medium voltage grids typically deliver power to groups of customers by means of Ring Main Units (RMU) like Figure 1, around 10 kV/400V transformers. This is a well-proven concept with switch disconnectors and fuses on both sides of the distribution transformer. For transformers above 630 kVA, circuit breakers can be preferred above fuses at locations D and E, because of the limited nominal current ranges of fuses.

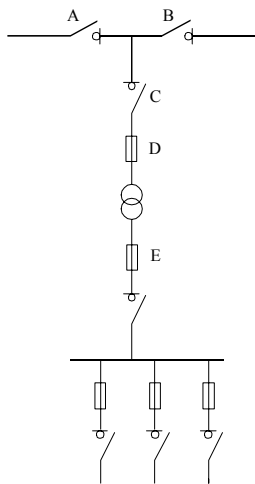

Fig. 1: Conventional set-up for a RMU.

In practice it is more often observed however, that the main low voltage protection (location E in Figure 1) is just kept away, leaving the protection of the distribution board completely to the fuse or circuit breaker on the high voltage side. This decision is probably motivated by efforts to reduce costs of equipment, and may be selectivity arguments.

Such philosophy can be acceptable as long as only the protection of conductors against conducting short circuit currents is required. However, in the case where an open arc is initiated in the low voltage distribution board, the protection on the high voltage side is mostly too slow to offer relevant protection against arcing effects.

In such situations explosive conditions have to be expected within the low voltage compartment of a ring main unit or a metal enclosed assembly on the low voltage side for an industrial application.

Even more dangerous situations can occur for industrial installations where the low voltage distribution is constructed with plastic insulation against the wall of a factory hall, because such locations are accessible to factory workers, walking alongside. Figure 2 shows the appearance of such a distribution [1], which is possible without short circuit protection between transformer and the main distribution installation.

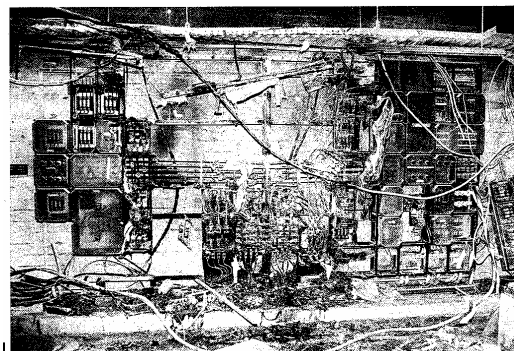

Fig. 2: Burned out Low Voltage Distribution Board after an arc fault.

Also when a circuit breaker is installed as a main protection of the low voltage board, arcing effects are

hardly limited when due to selectivity matters, the tripping delay is commonly set at the maximum delay value (e.g. 0,5 sec).

2. Recent accidents with fault arcs in the low voltage distributions

Some recent accidents can be mentioned for Dutch low voltage distributions without main low voltage protection. Figure 3 shows the basic set-up of such a configuration.

An industrial customer used two 10 kV connections with a coupling possibility between the low voltage distributions. Only the high voltage sides of the transformers were equipped with a power circuit breaker (A) or fuse. Circuit breaker A had settings $I_{>} = 300 \text{ A}$, $t_{>} = 5 \text{ min}$ and $I_{>>} = 600 \text{ A}$, $t_{>>} = 0.3 \text{ sec}$. On the low voltage side a switch disconnecter (B) was installed. (Sometimes installation drawings are confusing when switch disconnectors are wrongly presented like power circuit breakers with a cross!).

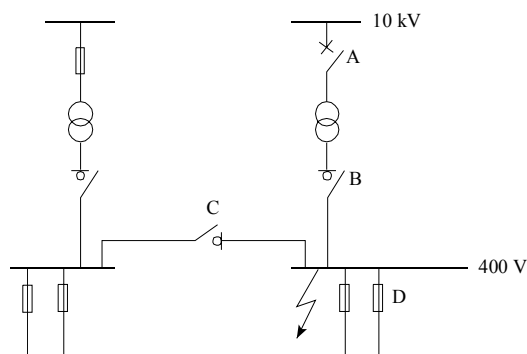

Fig. 3: Industrial installation with internal arcing

From this industrial installation a disturbance was reported recently.

When electricians arrived at the location, they noticed that the lighting on the terrain (fed by fuse D in figure 3) showed an irregular behaviour, lasting for at least more than ten minutes. From the main low voltage distribution big bangs were heard, while smoke was noticed. It was decided not to enter the distribution room but to send an alarm to the fire brigade, after which the fire was extinguished with CO_2 .

Now the main distribution was inspected. The rail system was heavily damaged, complete copper parts were disappeared. Especially near to grounded parts of the installation holes were formed, apparently because of fault arc effects.

An arc had apparently moved along the complete rail system, under influence of magnetic forces (Figure 4).

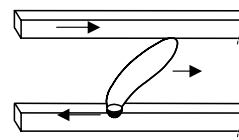

Fig. 4: Moving arc between rail system

The fault was finally interrupted by the circuit breaker on the high voltage side. The fault currents at the high voltage side were registered as slightly above 600A in the phases, while on the low voltage side the phase currents were about 15 kA. (Theoretically higher values up to 20 kA were expected from calculations based on the available short circuit power and the short circuit impedance of the transformer.) Considering the enormous destruction, it was concluded that the situation had lasted for many minutes, despite the settings of the protection. It is not unthinkable that the low voltage arcs reached such considerable lengths, that they resulted in a limiting effect on the current, preventing the high voltage relay to come into action. Further the arcs could have shown a temporarily extinguishing and restriking behaviour (the irregular functioning lighting installation, as mentioned in the above, was connected behind location D in Figure 3).

This assumption was based on open arc experiments in our laboratory, with phase voltage 303 V, where the setting of the test was 48 kA, and $\cos \Phi = 0.13$, while the measurement during the arcing test showed 35 kA and $\cos \Phi = 0.55$. The initial arc length was about 25 mm, but flashovers to grounded parts must have caused greater arc lengths.

Table 1 Current limitation effect by arcing

	Vphase [V]	Current [kA]	cosΦ
setting 1	303	48	0.13
measurement 1	303	35	0.55
setting 2	303	86	0.18
measurement 2	303	67	0.64

As a further practical example, recent Dutch arcing accident will be mentioned. The 630kVA transformer was protected by high voltage 50A fuses. At the low voltage side only a switch-disconnector was fitted as incomer of the metal enclosed assembly. So here again: no short circuit protection at the low voltage side of the transformer. At the low voltage site a theoretically short circuit current of 19 kA could be expected, based on the transformer and the short circuit power of the grid. Due to unclear reasons an internal arc was initiated in the metal enclosed assembly. The assembly was completely

destroyed; it took more than half an hour before the voltage was interrupted *manually*!

3. Comparison with former arc fault tests

Former arc fault tests [2] in the Kema laboratories, Arnhem, showed the minimal effect of high voltage protection against low voltage arc faults. Figure 5 shows the basic set-up for the tests.

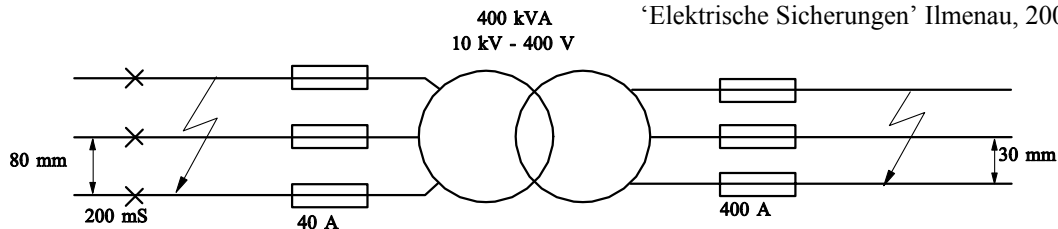

Fig. 5: Test set-up with fault arcs on both sides of a distribution transformer.

On the low voltage side of the transformer, 17 kA fault arcs were initiated. Arcing effects were minimal when low voltage fuses (400 A) were installed. The noise and visual effect increased enormously when during a next test, the low voltage fuses were removed, leaving the task of the interruption to the high voltage fuses (40A). Conditions became shocking when both low and high voltage fuses were removed, after which a high voltage circuit breaker with setting 200 ms performed the current interruption of the low voltage arcing fault. (Also the arcing effect on the high voltage side was investigated, but will not be discussed here).

4. Conclusion and recommendations

From recent field experiences and former laboratory experiments it can be concluded that for an acceptable protection against low voltage arc faults, low voltage fuses should be installed directly at the low voltage side of the distribution transformer, whenever the nominal current range allows such application. For transformers above 630 kVA a low voltage circuit breaker can be chosen as an alternative. In this case it shall be taken into account that the tripping delay of the circuitbreaker for short circuit shall be as short as possible.

Although one is generally afraid for selectivity problems in practice, arcing protection should be considered as an even more severe problem. Moreover with a well designed installation shorter delay times than the maximum setting for short circuit currents to guarantee selectivity are certainly possible. Whenever the high voltage side can be protected by fuses, these also have the preference above a breaker, from the standpoint of protection against arc faults. A more general overview of of arc fault effects and available protection methods like fast earthing and/or

circuit breakers operated by sensors, was presented elsewhere [3].

Literature

- [1] Moeller product brochure, Germany.
- [2] Pettinga, J.A.J.: "Protection against fault arcs" (in Dutch), *Energietechniek* 7/8, 1993, pp. 535-538.
- [3] Sloot, J.G.J.: "Current limiting fuses and other protection for reducing hazards". 1st Workshop 'Elektrische Sicherungen' Ilmenau, 2000.