

# Cooper Bussmann High Speed fuses

**COOPER** Bussmann

# High Speed Fuses – What for?

For the protection of semi-conductors or protection of *applications* with semi-conductors:

- Diodes
- Thyristors
- GTO's
- IGBT-modules

# Semiconductor basics

## Silicon Crystal structure + doping

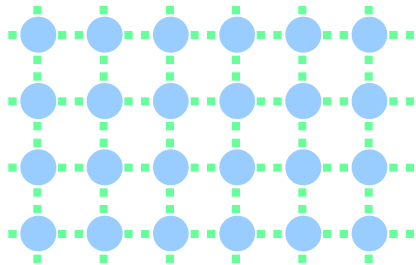

**Pure silicon**

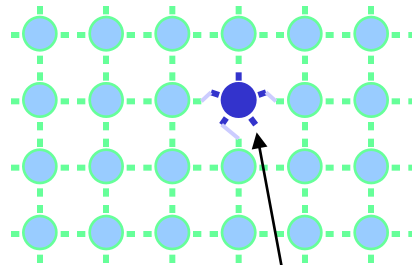

**Add group 5  
Material**  
(Phosphorus or Arsenic)  
**Spare electron**  
**N type**

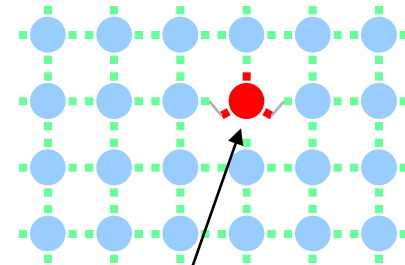

**Add group III  
Material**  
(Boron or Gallium)  
**hole**  
**P type**

# Basic semiconductor theory

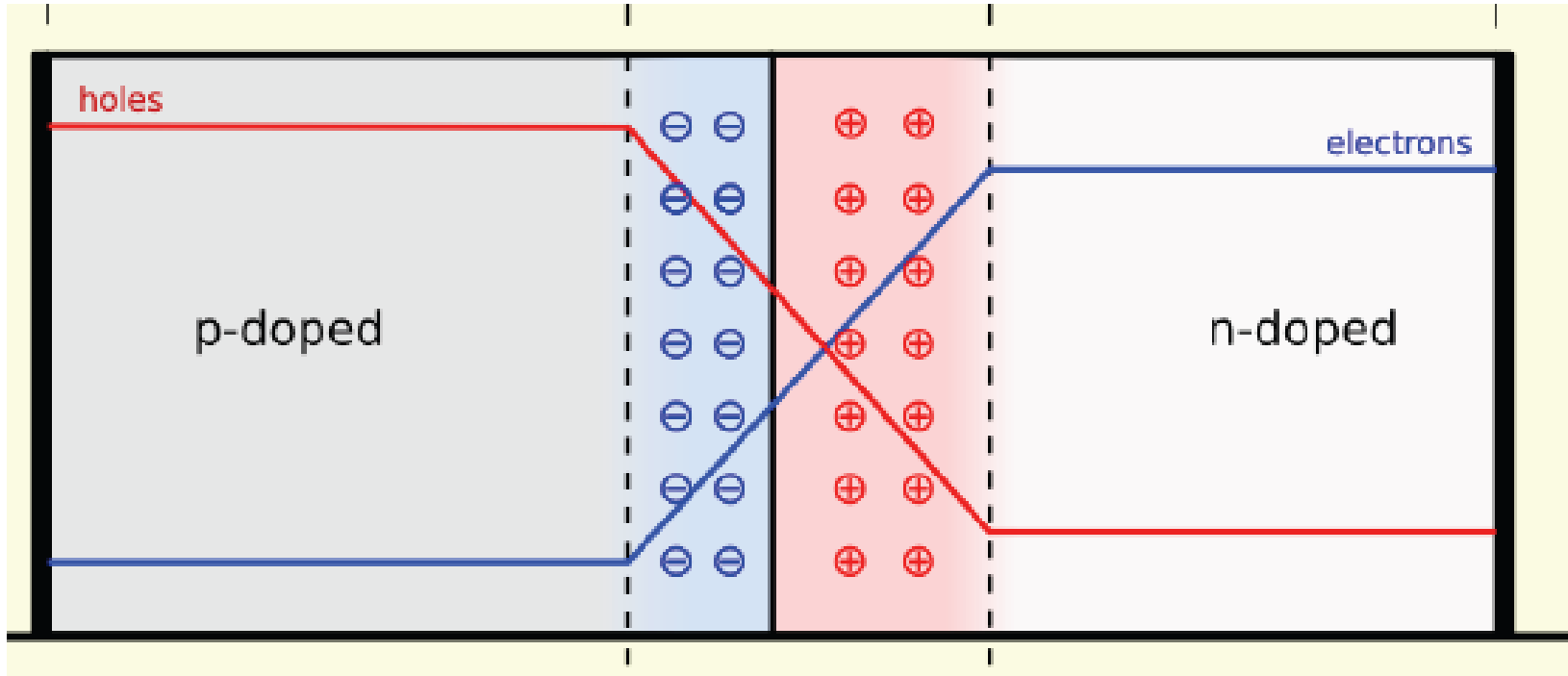

+

← electrons

-

Eg Battery

→  
Conventional current

# Feature of the application

- **Semiconductor devices are very sensitive to **over voltage** and **over current**, and require high protection speed**
- **The load current to be protected can be very high, like 5000A—6000A**

# Features of HSF

- **High speed operation**
- **Compact size**
- **Higher operation temperature**
- **Short circuit protection only**



# Standards

- **EN 60269 Part 4**
- **Defines Standard Tests and Methods**
- **Includes Dimensions**
  
- **Din 43 653 Dimensions for European Types**
- **Din 43 620 Dimensions for Blade Types**
  
- **UL 248 - 13**
- **Defines Standard Tests and Methods**

# HSF Families



**BS88**



North American



Ferrule



Square body



# British Style

- **240 Volt AC/150 Volt DC - 6 to 900 Amperes**
- **660 Volt AC/450 Volt DC - 6 to 700 Amperes**
  
- **Originally BS 88: Part 4 (ASTA reports)**
- **Now IEC EN 60269: Part 4**
  
- **UL Recognised**
  
- **Minimal energy let-thru ( $I^2t$ )**
- **Reasonable DC performance**
  
- **Accessories - Indicator System**



# Fuse Construction: British

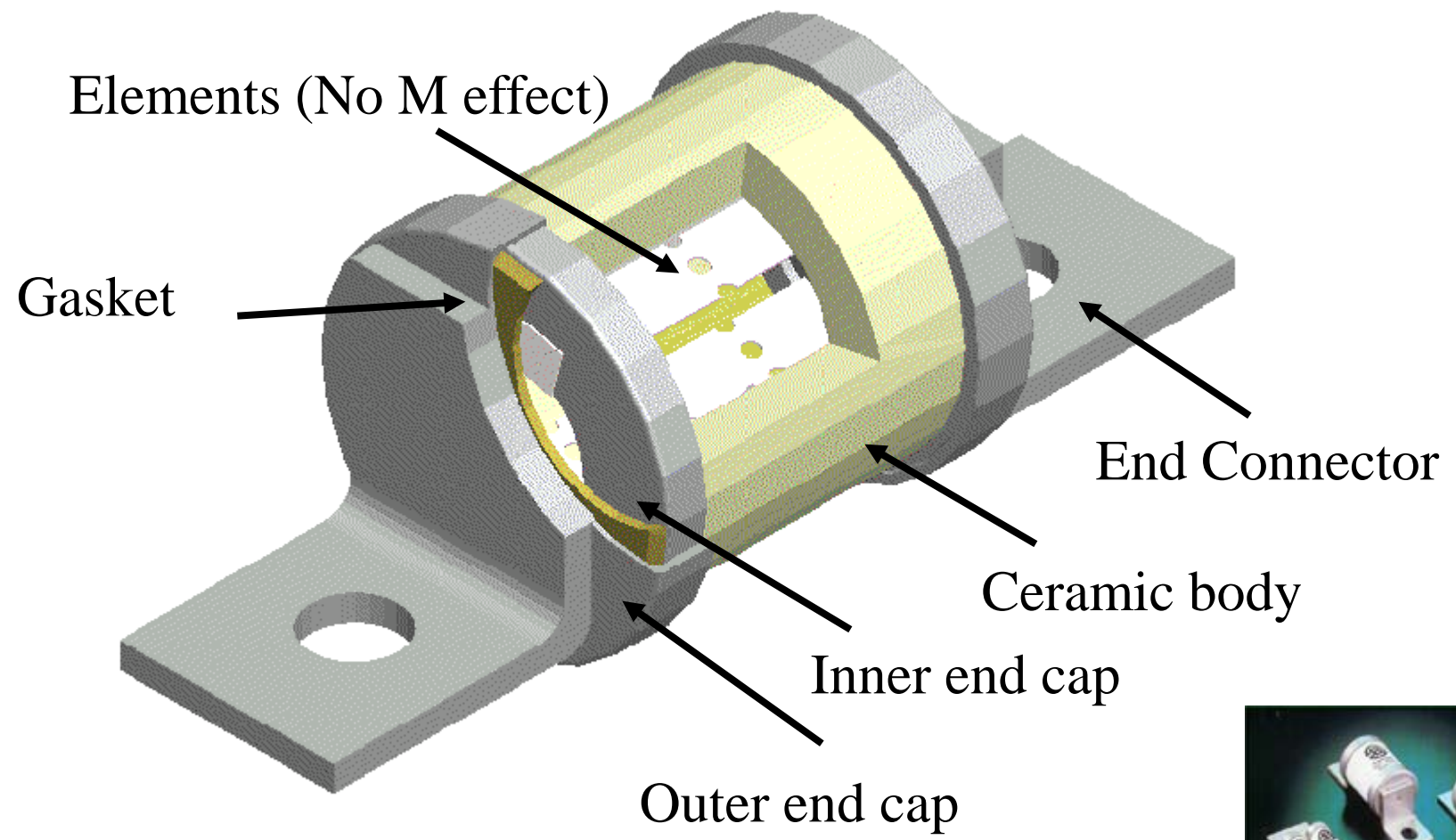



# British Style

## 240V (6-900A)



Type	Rated Current RMS-Amps
LCT	6 - 20
LET	25-180
LMT	160-450
LMMT	400-900

## 690V (6-700A)



Type	Rated Current RMS-Amps
CT	6 - 20
ET	25-32
FE	35-100
EET	90
FEE	100-200
FM	180-350
FMM	400-700

# HSF Families



BS88



North American



Ferrule



Square body



# North American Style



- Low energy let-thru ( $I^2t$ )
- Low watts loss
- Superior cycling capability
- Low arc voltage
- Excellent DC performance
  
- UL Component recognised
  
- Accessories - Fuseblocks

# Fuse Construction: North American

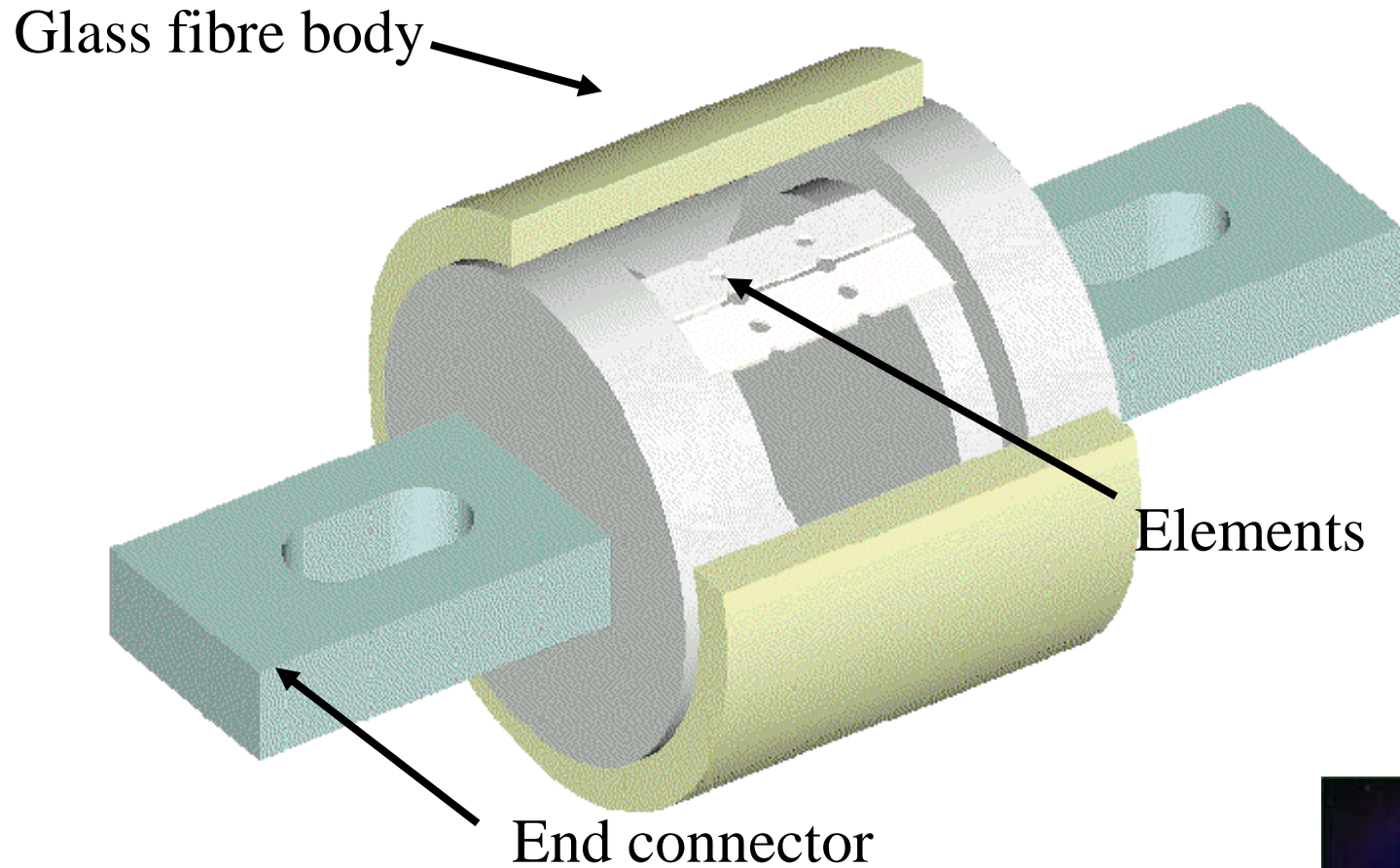

# North American Range

Type	Rated Current RMS-Amps	End Type
FWA 130Vac-130Vdc	1000-4000	Flush
FWA 150Vac/150Vdc	70-1000	Blade
FWX 250Vac/250Vdc	35-2000 35-800 1000-1200	Blade Flush
FWH 500Vac/500Vdc	35-1600	Blade
KAC 600Vac	1-1000	Blade
KBC 600Vac	35-800 35-60 800	Blade Flush
FWP 700Vac/700Vdc	35-1200	Blade
FWJ 1000Vac/700Vdc	40-2000	Blade

# HSF Families



BS88



North American



Ferrule



Square body



# Cylindrical (Ferrule) Style



- IEC 60269: Part 4
- UL Recognised
- Low energy let-thru ( $I^2t$ )
- Low power applications
- With and without indication

Accessories - fuse clips

fuse holders

fuse blocks

fused switches

# Cylindrical (Ferrule) Style

Voltage	Type	Diameter (cm)	Length (cm)	Current Rating
130Vac	FWA-A10F	10	38	5-30
	FWA-A21F	21	50	35-60
250Vac/250Vdc	FWX-A14F	14	58	5-30
500Vac	FWH-A6F	6.3	32	0.25-30
500Vac/500Vdc	FWH-A14F	14	50	1-4
	FWH-A14F	14	50	5-30
600Vac	FWC-A10F	10	38	6-32
700Vac	FWP-A14F	14	50	1-4
700Vac/700Vdc 700Vac	FWP-A14F	14	50	5-30
		14	50	32-50
700Vac	FWP-A22F	22	58	20-100
1000Vac/800Vdc	FWJ-A14F	14	70	20-30

# HSF Families



BS88



North American



Ferrule



Square body



# European (square) Style

- 660 Volt AC - 10 to 7500 Amperes
- 1250 Volt AC - 50 to 1400 Amperes
  
- IEC 269: Part 4
- UL Recognised
  
- Minimal energy let-thru ( $I^2t$ )
- Low operating temperature
- Low Watts loss



# Fuse construction: Square Body

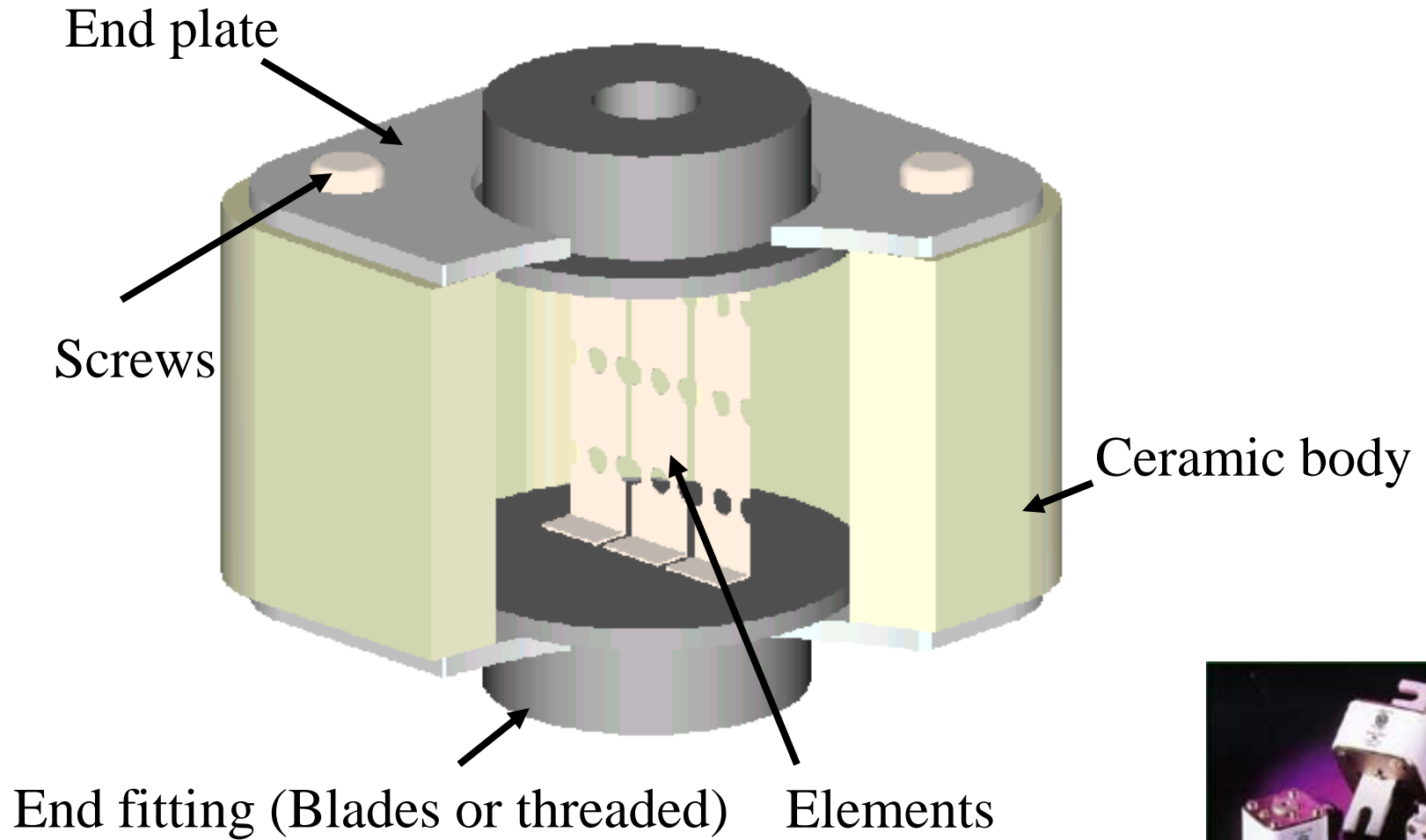



# European Square Style

- DIN 43 653
- North American Slotted  
Blade
- DIN 43 620
- Flush End (Metric/U.S.)
- French Style

# Connection styles

US Style

French Style

Flush End Contact

DIN 43 620

DIN 43 653

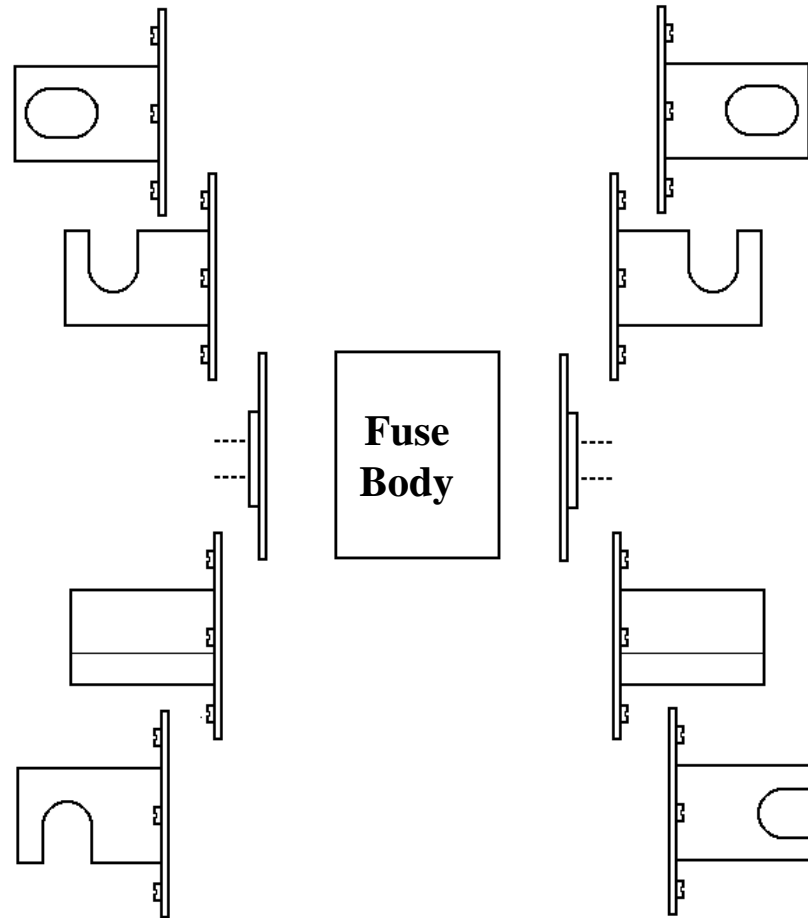

# Indicators & MicroSwitches



**SQUARE BODY FUSE  
INDICATORS**



**BS88 INDICATORS &  
Microswitch**



# Indicator versions

- No indicator
- Standard visual indicator
- T-type indicator
- K-type indicator



# Holders & Accessories

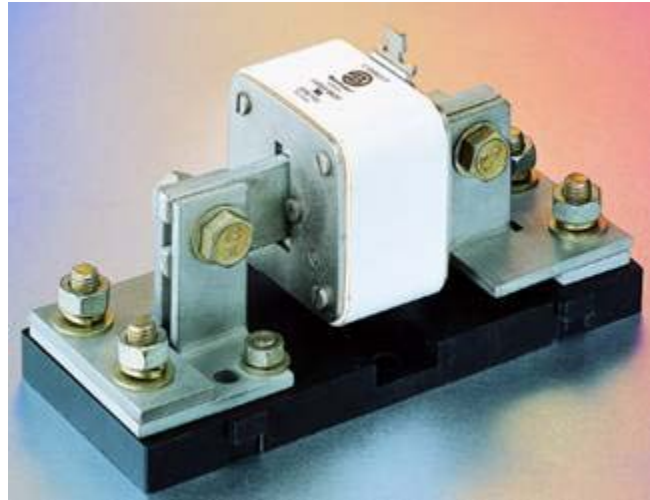

DIN 43653

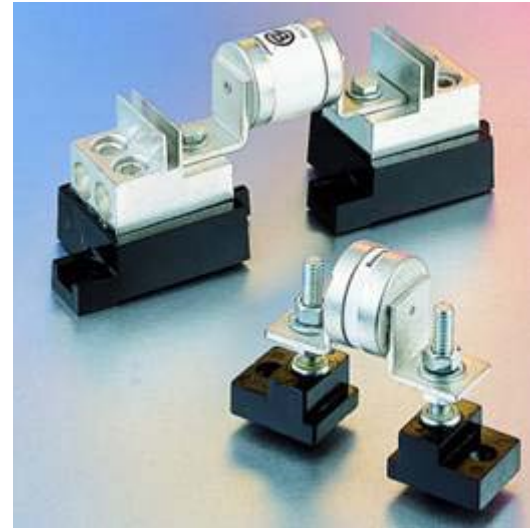

Universal



DIN 43620



Ferrule

# High current rectifier

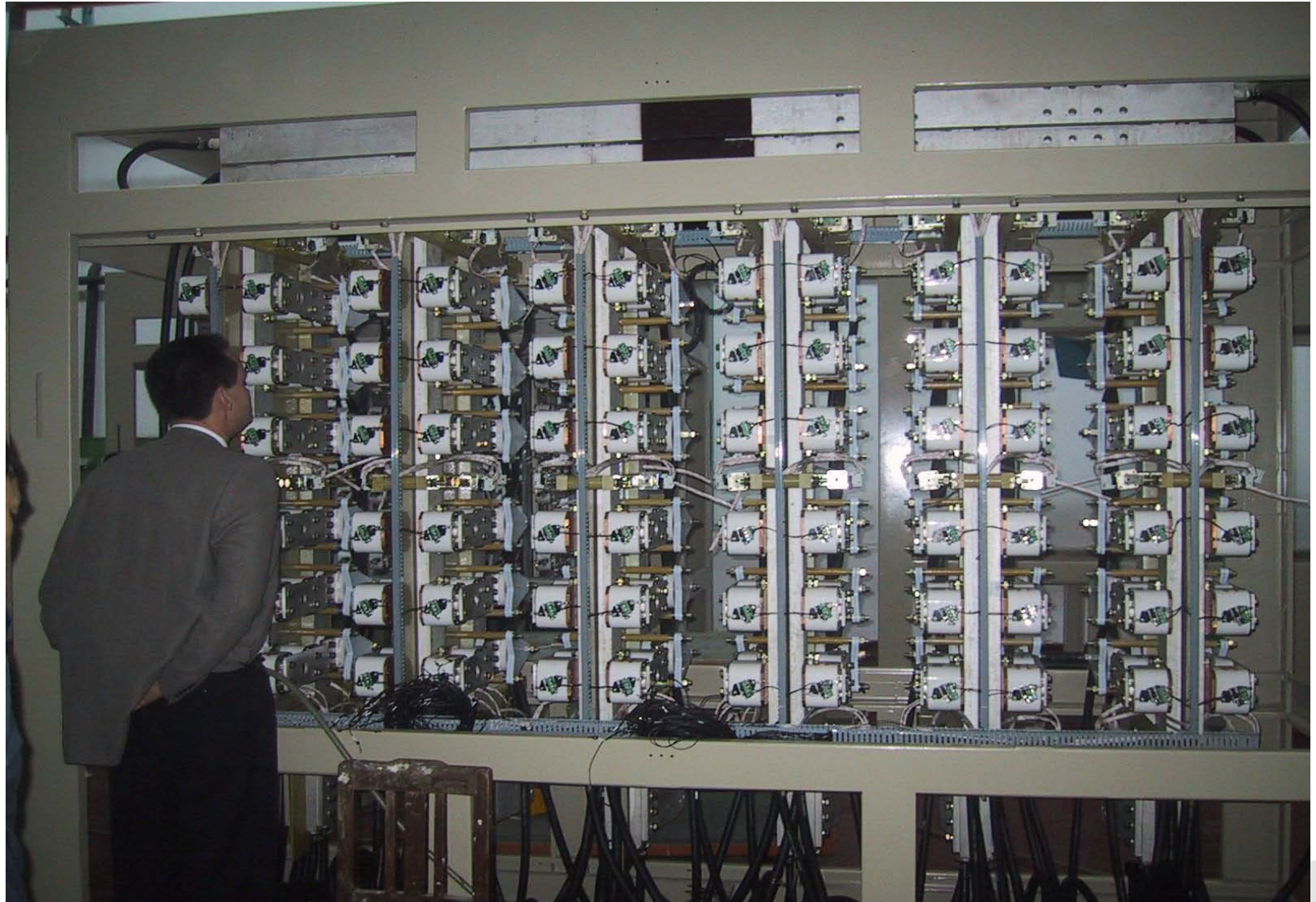

# Application examples

- Paper mills, conveyor belts



- Large factories, mass production



- Cranes or lifting equipment



- Industrial pumps



# • Xian Rectifier Unit - with diodes & fuses

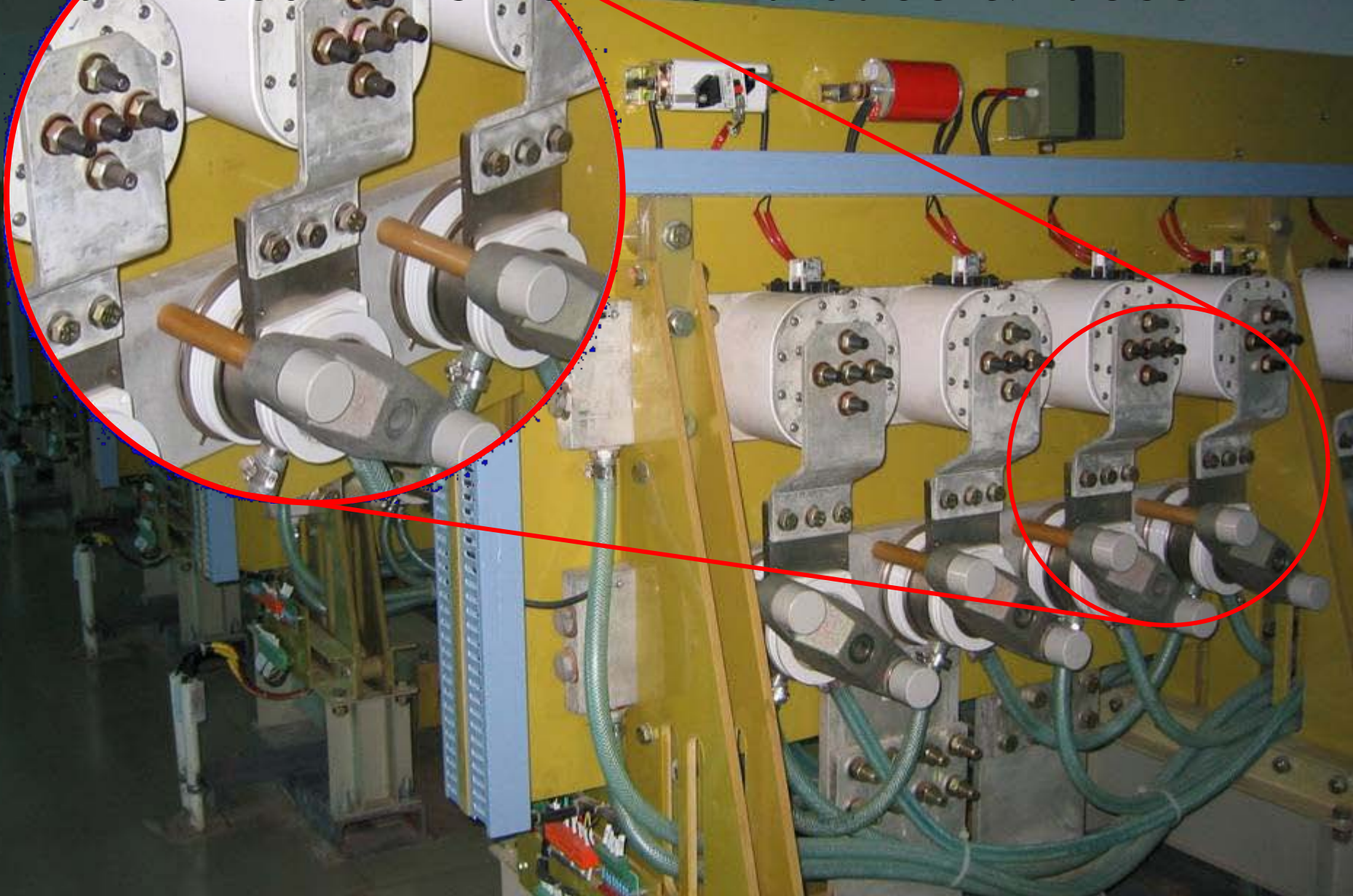

# Solar Applications

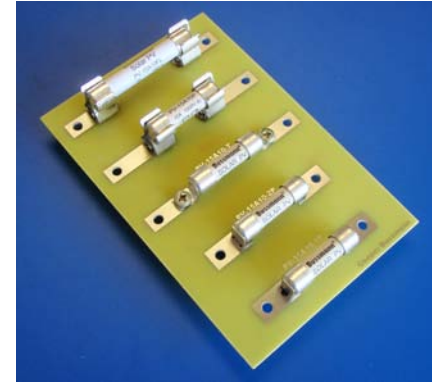

**First True Photo Voltaic Panel fuse**  
**Available now 8,10,12 and 15A variants**

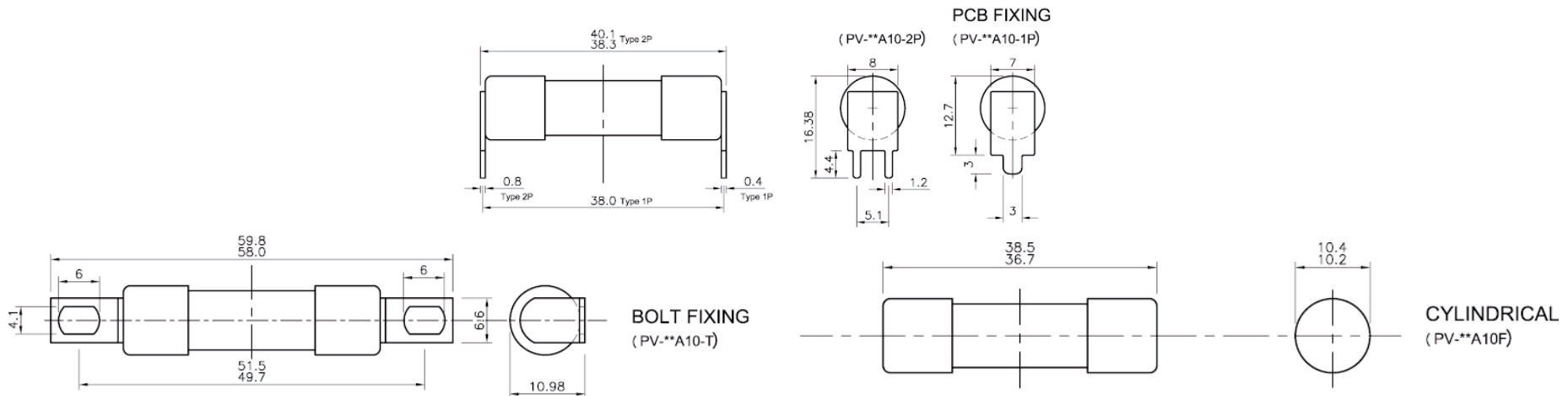

# Solar Applications

## **PV (Solar Panel) fuse-links**

**Rated voltage:** 1000V<sub>dc</sub>

**Amps:** 8A, 10A, 12A & 15A

**Rated breaking capacity:** 33kA dc

**Min Interrupting Rating:** 1.3x I<sub>n</sub>

**Min Interrupting Rating:** 4", 5" & 6" Solar Cells

**Time Constant (L/R):** under 1 ms

**Proven Cyclic performance**

**Full range of accessories available now**

Fuse holder parts

PCB clips 1A3400-09

Fuse block BM6031SQ

Modular holder CHM1D

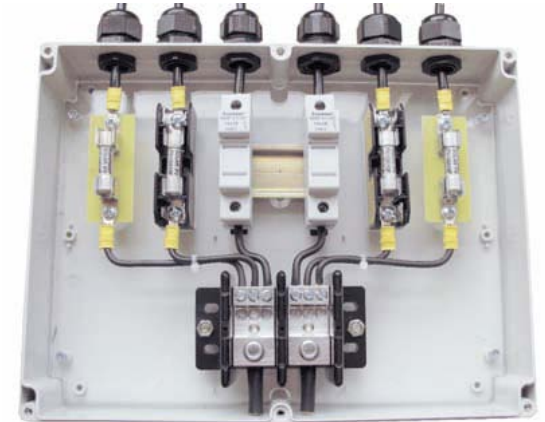

**Competitors Cannot Meet this Specification!!**

# High speed fuses

- **On existing installations the following questions are relevant**
- What is your High-Speed Fuse re-order procedure?
- How long can you be in a downtime situation?
- What is the downtime cost per minute at your company?
- Can you provide Part Numbers for substitutions?

**It is common for large installations to carry limited or no stocks of spare fuses**

 **End**